

UNI-T®

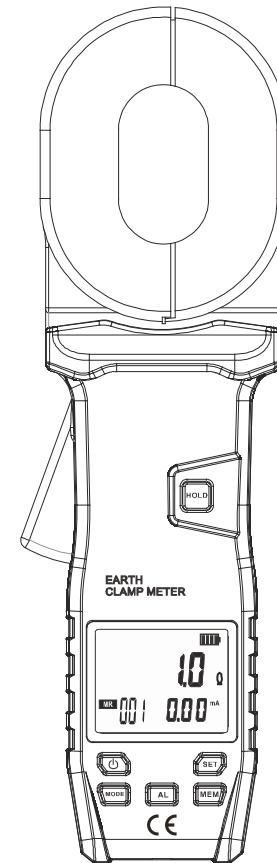
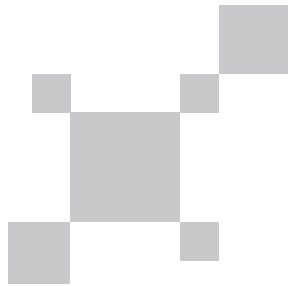

UT273+ UT275+

Operating Manual

Clamp Earth Resistance Tester

UNI-T®

UNI-TREND TECHNOLOGY (CHINA) CO., LTD.

No. 6, Industrial North 1st Road, Songshan Lake
Park, Dongguan City, Guangdong Province.

Post Code: 523 808

Tel: (86-769) 8572 3888

<http://www.uni-trend.com>

Made in China





Contents

I. Safety Information	2
II. Introduction	2
III. Models	3
IV. Range and Accuracy	3
V. Technical Specifications	4
VI. Structure	5
VII. LCD Display	5
VIII. Measuring Principle	6
IX. Operating Instructions	7
9.1. Power on/off	7
9.2. Check the battery voltage	7
9.3. Resistance and current testing	7
9.4. Clock and power-off time setting	8
9.5. Alarm setting	8
9.6. Data hold/storage	9
9.7. Data viewing/deletion	9
X. Battery Replacement	9
XI. Applications	10
11.1. Multipoint earthing system	10
11.2. Limited-points earthing system	10
11.3. Single-point earthing system	11
XII. Packing List	13

I. Safety Information

Thank you for purchasing this product, please read the user manual carefully before first use to avoid possible electric shock or personal injury. Please pay special attention to the safety when using the product.

- ✧ The product is designed, manufactured and inspected according to the IEC61010 Safety Regulations.
- ✧ To avoid error during measurement, please leave the clamp meter away from high-frequency signal generator, i.e. mobile phone
- ✧ Please pay attention to the texts and symbols at the label attached to the clamp meter.
- ✧ Check if the clamp meter and accessories are missed or damaged before use.
- ✧ Press and release the trigger once or twice before use to check if the clamp jaws are closed in place
- ✧ It is forbidden to use the clamp meter in flammable places, sparks may cause explosion.
- ✧ Do not press the trigger or clamp any conductor when the clamp meter is powered on.
- ✧ Only after the symbol “OL Ω” is displayed can the object to be measured be clamped.
- ✧ Never place or keep the clamp meter in places with high temperature, high moisture, dew and direct sunlight
- ✧ Please be sure that the clamp meter is in power-off state before replacing the battery.
- ✧ If the low battery symbol “” is displayed, please replace the battery in time, otherwise it can cause error.
- ✧ The contact area of the clamp jaws must be clean, do not wipe it with corrosives or coarse materials.
- ✧ Avoid impact on the clamp meter when opening the trigger, particularly the contact area of the clamp jaws.
- ✧ It is normal that the clamp jaws make slight noise when measuring resistance, the noise differs from the alarming sound “Beep—Beep-Beep”.
- ✧ Perform measurement according to the range and environment specified by the clamp meter.
- ✧ The current of measured conductor is not allowed to exceed the specified upper range.
- ✧ Only authorized qualified personnel can operate, disassemble, calibrate and maintain the clamp meter.
- ✧ If the clamp meter has the potential to cause danger during use, please stop using the clamp meter and seal it immediately, then sent it to authorized agency for maintenance.
- ✧ The signs “” labelled at the clamp meter and marked in the user manual warn that the user must perform operation safely according to the user manual.

II. Introduction

Clamp Earth Resistance Tester, also called Loop Resistance Tester, is used to test earth resistance, characterized by black display screen, simultaneous display of current and resistance, aesthetic appearance, wide range, high resolution, high performance, strong ability to resist interference, and, designed with shock-proof, dust-proof and moisture-proof structure. The tester has multiple functions such as clocking, data storage, data uploading, data viewing, alarming, auto power off and so on, making it an ideal tool for power and energy industries. Controlled by microprocessor, the tester can measure earth resistance accurately. Interference is minimized with fast filtering technology employed. It is widely

applied to perform earth resistance measurement on telecommunication, electric power, meteorology, machine room, oil field, power distribution line, tower transmission line, gasoline station, grounding grid, lightning rod, etc.

III. Models

Model	Resistance range	Current range
UT273+	0.010-600Ω	0.00mA-20.0A
UT275+	0.010-1000Ω	0.00mA-20.0A

IV. Range and Accuracy

Measurement Mode	Range	Resolution	Accuracy
Resistance	0.010Ω-0.199Ω	0.001Ω	±(1%+0.02Ω)
	0.20Ω-1.99Ω	0.01Ω	±(1%+0.05Ω)
	2.0Ω-49.9Ω	0.1Ω	±(1%+0.5Ω)
	50.0Ω-99.5Ω	0.5Ω	±(1.5%+1Ω)
	100Ω-199Ω	1Ω	±(2%+2Ω)
	200Ω-395Ω	5Ω	±(5%+5Ω)
	400-590Ω	10Ω	±(10%+10Ω)
	600Ω-880Ω	20Ω	±(20%+20Ω)
	900Ω-1000Ω	30Ω	±(25%+30Ω)
Current	1.00mA -9.99mA	0.05mA	±(2.5%+1mA)
	10.0mA -99.9mA	0.1mA	±(2.5%+5mA)
	100mA -999mA	1mA	±(2.5%+10mA)

	1.00A-9.99A	0.01A	±(2.5%+0.2A)
	10.0A-20.0A	0.1 A	±(2.5%+0.5A)

Note:

1. Within the temperature range used, the “testing accuracy × 0.1/°C” is added (out of the range between 18°C to 28°C)
2. The rate of change of ambient temperature shall be lower than 0.5°C per minute.

V. Technical Specifications

Function	Earth resistance, loop resistance and leakage current tests.
Ambient temperature and humidity	23°C±5°C, <75%rh
Power supply	DC 6V (4 ×1.5V AA alkaline battery)
Measurement mode	Mutual inductance
Resistance resolution	0.001Ω
Current resolution^①	0.01mA
Jaw size	55mm×32mm
Clock function	√
Simultaneous display	Simultaneous display of Resistance and Current test results
Display mode	4-digit LCD display designed with black screen
LCD size	46mm×36mm
Tester dimensions	285mm×85mm×58mm (L*W*H)
Measurement time	Once per second
USB port	Designed with USB port for data uploading, storing and printing
Communication cable	USB cable (data transmission, 1pcs)
Data storage	500 groups (with the symbol “MEM” displayed and flashed to indicate full storage)
Data viewing	“MR” is displayed
Overrange indication	“OL” is displayed
Interference test	Identify interference signal automatically, with the symbol “NOISE” being indicated when large interference current occurs.
Alarm function	The tester alarms if measurement value is over the threshold set.
Battery voltage	Battery power displaying in real time
Auto power off	Automatically power off can be set at 5, 10, 15, 20 minutes. OFF means disabling APO function, the default time is 5 minutes.
Power consumption	110mA Max
Weight	Tester: 1180g (Battery included)
Operating temperature and humidity	-10°C~40°C; <80%rh
Storage temperature and humidity	-20°C~60°C; <70%rh
Insulation resistance	>20MΩ (500V between circuit and casing)
Voltage withstanding	AC 3700V/rms (between circuit and casing)
External magnetic field	<40A/m

External electric field	<1V/m
Safety regulations	IEC61010-1 (CAT III 300V, CAT IV 150V, Pollution degree: 2); IEC61010-031; IEC61557-1 (Earth resistance)

Note①: Current function is designed for UT273+ and UT275+ only.

VI. Structure

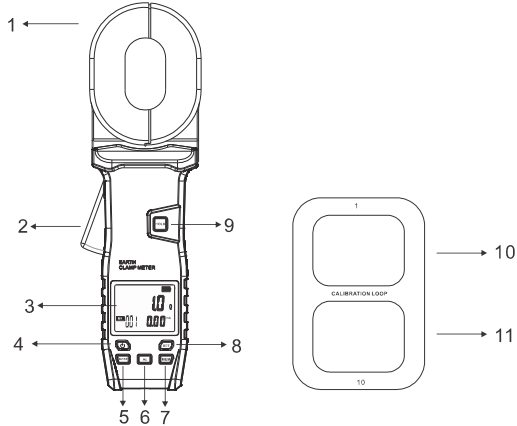

- 1. Clamp jaws
- 2. Trigger
- 3. LCD display screen
- 4. Power button
- 5. Mode button
- 6. Alarm button
- 7. Storage button
- 8. Setting button
- 9. Hold button
- 10. Calibration loop at 1Ω
- 11. Calibration loop at 10Ω





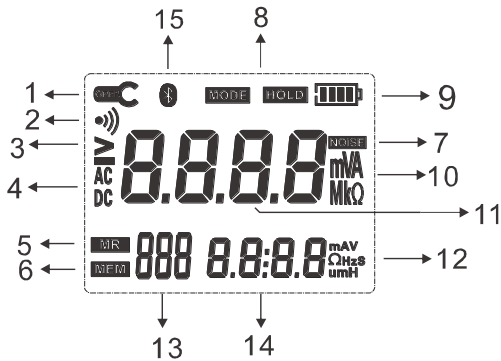

Note②: Bluetooth function is designed for UT275+ only.

VII. LCD Display



- | | | |
|-------------------------------------|--------------------------------|------------------|
| 1. Jaws opened | 2. Alarm indication | 3. Greater than |
| 4. AC/DC current | 5. Data viewing | 6. Data storage |
| 7. Noise indication | 8. Data hold | 9. Battery power |
| 10. Units | 11. 4-digit resistance reading | 12. Units |
| 13. Number of group of storage data | 14. 4-digit current/clocking | 15. Bluetooth |

Symbol descriptions

- (1). : This symbol displays when clamp jaws are opened, indicating the jaws are triggered to open by user, or the clamp jaws are polluted severely (stop use for this situation).
- (2). : This symbol indicates low battery, please replace the battery for ensuring measurement accuracy.
- (3). "OL Ω" indicates the measured resistance is over the specified upper range.
- (4). "L0.01Ω" indicates the measured resistance is below the specified lower range.
- (5). "OL A" represents the measured current exceeds the specified upper range.
- (6). : If the measured value is greater than the threshold, this symbol flashes, accompanied by intermittent sound "Beep—Beep--Beep".
- (7). : This symbols flashes when performing data hold.
- (8). : When viewing data, this symbol and group number are displayed simultaneously.
- (9). : If large interference current occurs at the measured earth loop, this symbol displays, along with indication sound "Beep—Beep--Beep". The accuracy of the testing cannot be ensured in such situation.
- (10). "Er": This symbol indicates the trigger is set off, there is object at the clamp jaws, or the clamp jaws are opened.

VIII. Measuring Principle

The basic measurement principle used for the tester is measuring loop resistance, see the figure below. The clamp jaws are composed of voltage and current coils, the voltage coil provides excitation signal and induces a potential **V** in the measured loop. Under the action of the potential **V**, the current **I** will be generated at the measured loop. Measure **V** and **I** through the tester, and then the measured resistance **R** will be obtained according to the formula below:

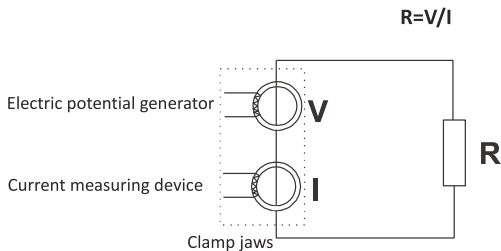

$R = V / I$

IX. Operating Instructions



9.1. Power on/off

	Do not press the trigger, open the jaws or clamp any conductor during powering on the tester.
	Only after “OLΩ” is displayed can the trigger be pressed to clamp the measured conductor.
	Before powering on the tester, please press and release the trigger once or twice to ensure the jaws can be opened and closed well.
	During power-on, please keep the tester in static state, do not turn it over, or do not exert external force on the jaws. Otherwise the measurement accuracy cannot be ensured.

Press the power button to turn on/off the tester. The tester performs self calibration when it is powered on, after powered on, “**OLΩ**” will be displayed and then the tester enters resistance measurement mode. If the tester cannot be turned normally, the symbol “**Er**” will be displayed to indicate power-on error, the common causes of the error may be that the clamp jaws are not closed in place, and that the jaws clamp the measured conductor when the tester is powered on, and others.

After the tester is turned on, it will automatically power off at the time set. The tester will flash for 30 seconds before it powers off automatically, if the power button is pressed again, the APO time will be extended.

9.2. Check the battery voltage

If the symbol “” is displayed after the tester is powered on, it indicates low battery, please replace the battery in time to ensure measurement accuracy. The symbol “” will flash to indicate the tester will be powered off soon.

9.3. Resistance and current testing

	If the measured earth resistance is considered to be abnormal, please check the tester through the supplied calibration loop rated at 1Ω and 10Ω.
---	--

After self calibration is completed, “**OLΩ**” will be displayed to indicate resistance measurement can be performed. Press the trigger to open the jaw, and clamp the measured loop, then read the result.

Resistance and earth leakage can be measured simultaneously. Press “**MODE**” to switch between “Resistance + Current” and “Resistance + Clock”.

“**OLΩ**” shows up to indicate the measured resistance is over the specified upper range.

“**L0.01Ω**” shows up to indicate the measured resistance exceeds the specified lower range.

In “Resistance + Current” mode, the current value will show at the lower right of the display screen, i.e. “**0.00mA**”. To measure current, please switch to this mode.

In “Resistance + Clock” mode, the earth voltage value will show at the lower right of the display screen, i.e. “**12: 00**”. To read the current time, please switch to this mode, the time needs to be reset if the

battery is replaced.

“Resistance + Current” mode:



Measured resistance: 0.51Ω

Number of group of stored data: 1

The current of measured loop: 0.00mA

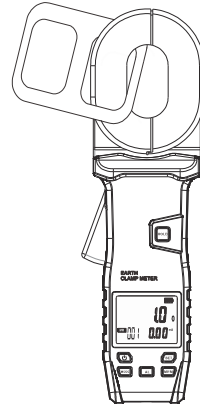

“Resistance + Clock” mode:



The measured resistance exceed the lower range.

Number of group of stored data: 8

Current time: 12:08

9.4. Clock and power-off time setting

After the tester is powered on, long press “**SET**” button to enter the setting mode. The figure in lower left of the display screen is the power-off time set, short press “**HOLD**” button to adjust the power-off time to 5, 10, 15, 20 minutes or OFF (OFF represents disabling APO).

The figure in the lower right of the display screen is the time set. Short press “**SET**” to switch between “Year”, “Month and Day” and “Hour and Minute” setting interfaces, and short press “**MODE**” to select the digit to be adjusted (the selected digit will flash), and then short press “**MEM**” or “**AL**” to increase or decrease the value, after that, long press “**SET**” to save the set value and exit.



Fig. 1: In 2020



Fig. 2: On 18 Dec.

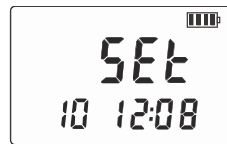



Fig. 3: At 8 past 12

9.5. Alarm setting

After the tester is turned on, short press “**AL**” to enable or disable the alarm function.

Long press “**AL**” to set resistance and current alarming values, short press “**HOLD**” to select the digit to be adjusted (the selected value will flash), and short press “**SET**” or “**MEM**” to increase or decrease the value, and then short press “**MODE**” to switch alarm mode, after that, long press “**AL**” to save the set value and exit.

If the measured resistance is greater than the alarm threshold set and the alarm function is enabled, the symbol “A digital display showing a resistance measurement of 20.0 Ω. On the left, there is an alarm symbol consisting of a bell and three curved lines. On the right, there is a battery level indicator with four bars, the top two of which are filled.

9.6. Data hold/storage

If “**HOLD**” is short pressed when the measurement is stable, the present data will be locked and saved, with the symbol “**MEM**” flashing once and numbering performed. If the data storage is full, the symbol “**MEM**” will flash, short press “**HOLD**” to exit the data hold mode. See the figure below, the symbol “**MEM**” is the symbol that flashing during data storage; the symbol “**HOLD**” indicates the present data locked.

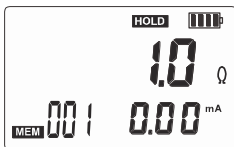

9.7. Data viewing/deletion

After the data are stored, short press “**MEM**” to enter data viewing mode, the symbol “**MR**” displays on the data viewing interface. Short press “**SET**” or “**AL**” to set 1 as step value to select number of group of stored data, or long press “**SET**” or “**AL**” to set 10 as step value to select number of group of stored data. Short press “**MEM**” to exit data viewing mode. The data viewing mode is shown in the figure below, the present number of group viewed is 1.



In data viewing mode, long press “**MEM**” to enter data deletion mode, short press “**AL**” to delete the data stored, and then short press “**SET**” to undelete the data.

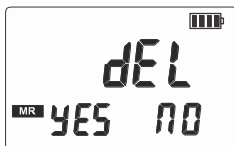

X. Battery Replacement

If the battery power is low, the symbol “

- 9 -

XI. Applications

11.1. Multipoint earthing system

Connect multipoint earthing systems (power-transmission tower, communication cable, building, etc.) with aerial earthing wire (shielding layers of communication cables), as shown in the figure to the left. If performing measurement with clamp meter, the equivalent circuit diagram is shown in the figure on the right.

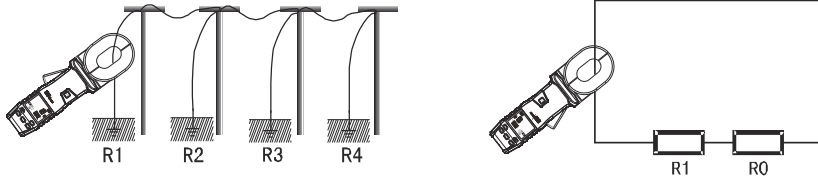

Where:

R1 is the predicted earthing resistance.

R0 is the equivalent resistance of the parallel earthing resistance of all other towers.

In earthing theory, R0 is not the parallel value in electrotechnics as there is so called “Mutual resistance” (R0 value is slightly greater than the parallel value in electrotechnics), but the earthing semisphere of each tower is much smaller than the distance between towers, and the quantity of earthing point is very large, leading R0 to be much smaller than R1. Hence, from engineering viewpoint, the assumption can be reasonably made as R0=0.

After performing comparison tests (compared with conventional methods) multiple times in different environments and places, the assumption above is proved to be reasonable.

11.2. Limited-points earthing system

The limited-points earthing system is common, for instance, some towers (5 towers) are connected with aerial earthing wire; the earthing system of certain building is not an independent grounding grid, but, is formed by connecting several grounding electrodes through conductors.

In such situation, if R0 is assumed as 0 (as shown in the figure above), it will cause large error to the measurement result.

Considering the reason above, the effect of mutual resistance is neglected, and the equivalent resistance of parallel earthing resistance is calculated according to common method, thus, for earthing system with N electrodes (N is a relative small value, but greater than 2), N equations can be listed as below:

$$R_1 + \frac{1}{\frac{1}{R_2} + \frac{1}{R_3} + \dots + \frac{1}{R_N}} = R_{1T}$$

$$R_2 + \frac{1}{\frac{1}{R_1} + \frac{1}{R_3} + \dots + \frac{1}{R_N}} = R_{2T}$$

.

$$R_N + \frac{1}{\frac{1}{R_1} + \frac{1}{R_2} + \dots + \frac{1}{R_{(N-1)}}} = R_{NT}$$

Where:

R1, R2,RN refers to the earthing resistance of N grounding electrodes.

R1T, R2T,RNT is the resistance measured at the branch earthing circuit through clamp meter.

This is a nonlinear system of equations containing N unknown values and N equations, which can be solved, but without dedicated calculation program software, it is difficult or even impossible to solve if the value of N is relatively large, so please purchase our dedicated program calculation software to solve the nonlinear system of equations in computers or laptops.

In principle, except for neglecting the mutual resistance, this method does not neglect the measurement error caused by R0. Please note that, the number of testing value measured must be equal to the number of mutually-connected grounding electrode in the earthing system, so as to calculate through the program. The program also outputs same number of earthing resistance.

11.3. Single-point earthing system

In principle, the clamp meter can measure loop resistance only, but it cannot measure single-point earthing system. User can create a loop for test using a test lead and a grounding electrode around earthing system. Two methods to measure single-point earthing system are introduced below, these methods can be employed to places where test cannot be performed through conventional voltage-current method.

(1). Two-point method

Find an independent well-earthed grounding electrode RB (i.e. water pipe, building, etc.) around the measured grounding electrode RA, then connect RA with RB through a test lead, see the figure below:

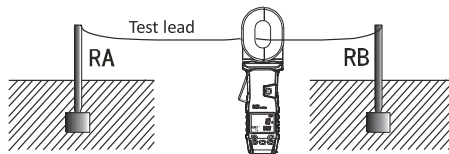

The resistance measured by the clamp meter = Resistance of RA + Resistance of RB + Resistance of test lead, that is, $R_T = R_A + R_B + R_L$

Where:

RT is the resistance measured by the clamp meter

RL is the resistance of test lead

To measure the resistance RL of test lead, please measure it with its both ends connected.

So, if the measured value is lower than the allowed earthing resistance, then the earthing resistance of these two grounding electrodes are qualified.

(2). Three-point method

Find two independent grounding electrodes (RB and RC) around the measured grounding electrode RA, as shown in the figure below:

Step 1: Connect RA with RB through a test lead, then read the first data R1 from the clamp meter, see the figure below:

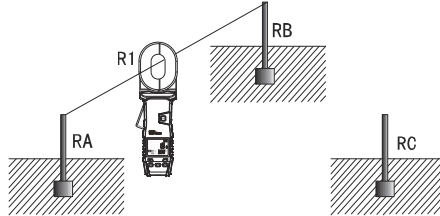

Step 2: Connect RB with RC through a test lead, then read the second data R2 from the clamp meter, see the figure below:

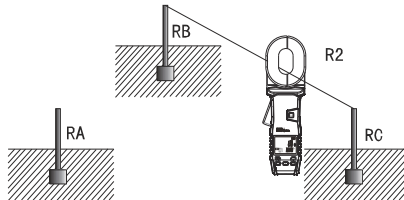

Step 3: Connect RC and RA through a test lead, then read the third data R3 from the clamp meter, see the figure below:

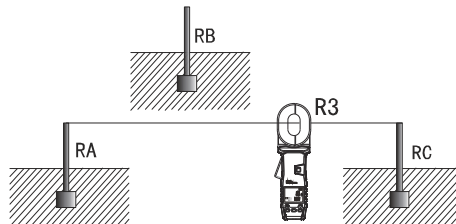

As the readings above are serial resistance of the two grounding electrodes, we can easily calculate and obtain each earthing resistance:

Given $R1=RA+RB$, $R2=RB+RC$, $R3=RC+RA$

So $RA = (R1+R3-R2) \div 2$

This is the earthing resistance of grounding electrode RA. To facilitate understanding the formulas above, we can regard these three grounding electrodes as a triangle, then the measured resistance is:
Measured resistance = (Resistance of adjacent side 1 + Resistance of adjacent side 2 - Resistance of opposite side) ÷ 2

The resistances of the two reference grounding electrodes are:

$$R_B = R_1 - R_A, R_C = R_3 - R_A$$

XII. Packing list

Clamp meter	1 pc
Battery	4 pcs (1.5V AA alkaline battery)
Calibration loop	1 pc
USB cable	1 pc (data transmission)
User manual	1 pc
Tool box	1 pc

Note:

The company is not responsible for other losses caused by use.

The content of this user manual cannot be used as a reason for using the product for special purposes.

The company reserves the right to modify the contents of the user manual. If there are changes, no further notice will be given.